

P-650 Card+PIN Proximity Reader & Keypad

The **P-650 Card+PIN Proximity Reader & Keypad** combines a Pyramid Series reader and a stainless steel Essex Keypad™ into one attractive package. The P-650 reader is designed for use in applications requiring a secondary verification, an individual requesting access to a secure area must have both a valid proximity access credential and a valid Personal Identification Number (PIN). The P-650 is designed for mounting on a flat, non-metal surface or on a standard U.S. single-gang electrical box.

The electronics for the P-650 reader is housed in a weatherproof, shock resistant package. This package is mounted to the installation surface.

The P-650 reader is compliant with the following organizations: FCC, , and .

1.0 HID Compatibility

Pyramid Series readers can be configured in the factory to read HID's standard proximity access control cards, including the ProxCard II, ISOProx II, and ProxKey II in 26-bit Wiegand formats, as well as all Pyramid Series credentials. Readers configured to be HID compatible, an optional feature, will have the following sticker on the back side of the reader.



HID compatible readers do not require any special wiring connections. There might be read range differences between HID cards and Pyramid Series credentials. The reader will beep and flash twice to indicate it has read a non standard HID card.

NOTE: If you are enrolling cards for a "hybrid" site (one using both Pyramid series and HID credentials), it is possible to have duplicate card coding (i.e. identical format, facility code, and ID number).

P-650 Card+PIN Proximity Reader & Keypad

2.0 Reader Specifications

Table 1: Reader Specifications

| | Dimensions | Operating Voltage | Operating Temperature | Frequency | Audio Tone | LED Indicator |
|--------------|---|---------------------------------------|---|-----------------------|------------|--|
| P-650 | 4.4" H x 3.9" W x 0.95" D (112 mm H x 99 mm W x 24 mm D) | 5 to 14 VDC @ 100 mA nominal | - 40°C to +65°C (- 40°F to +150°F) | 125 KHz excitation | standard | 4-state: Red, Green, Amber, Off |

2.1 Read Range

Read range is measured in a clean RF and electrical environment using a Pyramid Series Standard Light Proximity Card (PSC-1) presented parallel to the reader surface with the reader operating at 12 VDC. A good quality, regulated, linear power supply is recommended for use with all proximity readers.

Table 2: Read Range

| | Standard Light Proximity Card | Multi Technology Card | Proximity Key Ring Tag |
|---------------|-------------------------------|---------------------------|---------------------------|
| PS-600 | up to 4 inches (102 mm) | up to 3 inches (76 mm) | up to 2 inches (51 mm) |

Due to the physical size difference between the coils of various credentials, Multi Technology Proximity Cards (PSM-2) and Proximity Key Ring Tags (PSK-3) provide less read range than Standard Light Proximity cards (PSC-1) –approximately 75% less and 50% less respectively. Read range will be reduced if a reader is located in electrical or RF noisy environments such as mounted near a computer monitor, powered by a switching power supply, or a lack of a good earth ground. Operation at 5 VDC will result in shorter read range.



P-650 Card+PIN Proximity Reader & Keypad

2.2 Cable Requirements

The P-650 reader operates with up to 500 feet (152 m) of cable, using seven-conductor, shielded, stranded cable. Per Wiegand specification, AWG 24 (such as Belden 9537) is the minimum gauge required for data transfer in a 500-foot run length. However, the proper wire gauge to use must be determined by the current draw requirements of the reader, the length of the cable run, and the voltage being applied to the reader.

If the reader is to be operated at 5 VDC, 5 VDC must be available at the reader (long cable runs have a voltage drop due to the resistance in the cable). A larger gauge of wire (having less resistance) or a separate power supply near the reader may be required to ensure 5 VDC is available at the reader.

3.0 Reader Configuration

There are no switches or jumpers to set. All connections needed to support the reader are made through the reader's cable. Please consult the Wiring Connections section on page 5 for wiring instructions.

3.1 P-650 Card+PIN Reader Mounting Instructions

When mounting to a flat surface, three holes need to be drilled to mount the P-650's electronics package (refer to Figure 1). One large hole (1 inch - 25.5 mm) accommodates the beeper and the reader cable (please note that the beeper and reader cable hole is not located on the reader's center line). Two small pilot holes for a #6 screw (1/8 inch - 3 mm) are for mounting the electronics package on a wall surface.

Drilling is not required if the reader is to be mounted to a standard U.S. single-gang electrical box - the electronics package is mounted directly to the electrical box.

P-650 Card+PIN Proximity Reader & Keypad

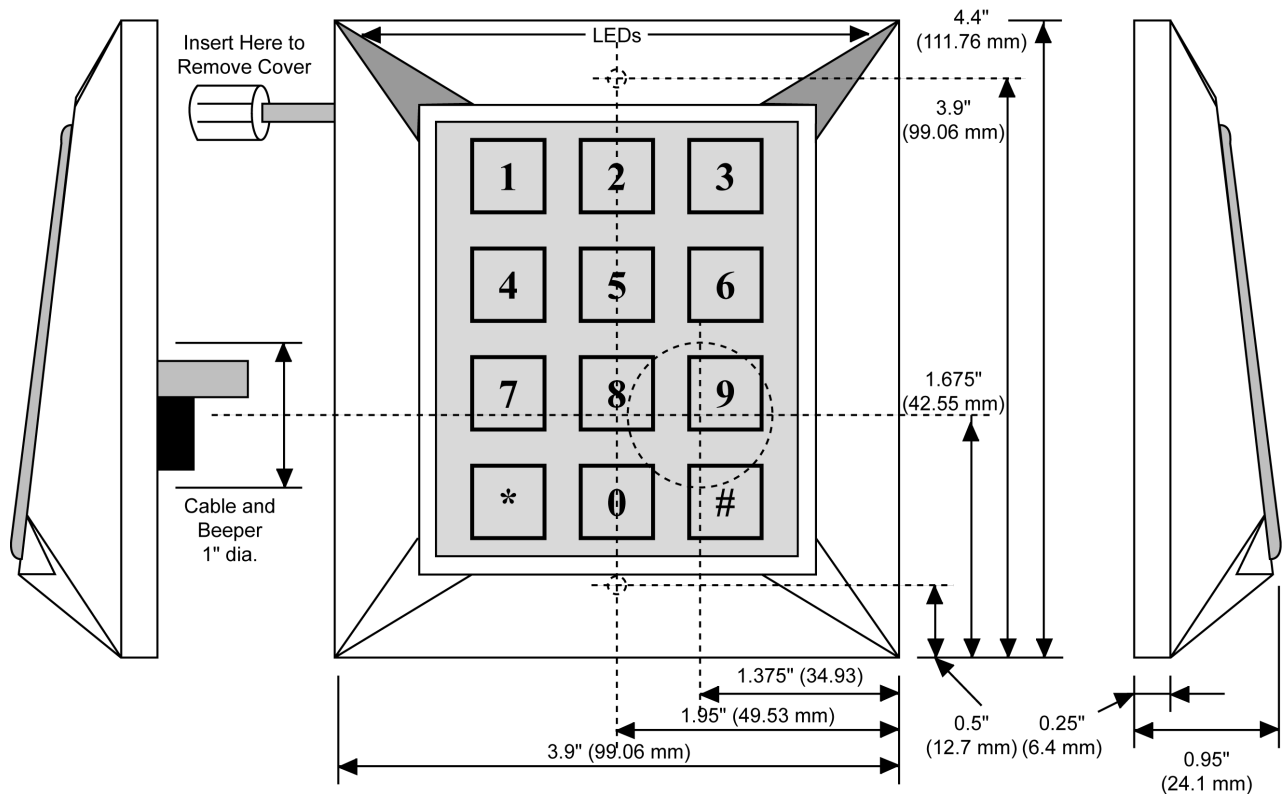

Figure 1: P-650 Mounting Diagram

3.2 Installing the Front Cover Bezel

Once the electronics package is installed, simply align one corner of the front cover bezel with the mounted package and gently press it into place. To remove the front cover bezel, slip a thin blade screwdriver just inside the bezel (see the location identified in Figure 1). Gently twist the screwdriver to pop the front cover bezel loose – using excessive force when removing the front cover bezel can damage the reader's LED.



P-650 Card+PIN Proximity Reader & Keypad

3.3 Wiring Connections

Refer to Figure 2 for instructions for wiring the P-650 reader to a Wiegand access panel.

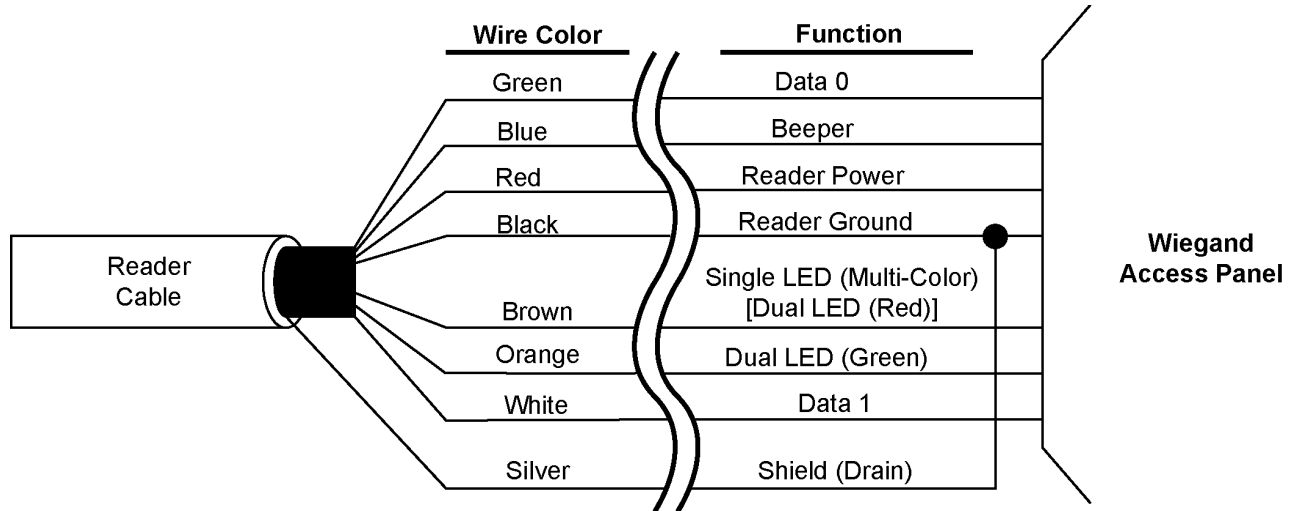

Figure 2: Wiegand Reader Wiring Connections

4.0 Installation Verification

The following information applies to an installation with an access panel. Refer to the [Troubleshooting the Reader Installation](#) section beginning on page 9 if the reader is not functioning properly.

4.1 Grounding

Shield (Drain) continuity must run from the reader to the access panel. Shield (Drain) and reader ground should tie together at the access panel and connect to an earth ground in one place.

4.2 Power

The reader is normally powered by the Wiegand controller, however, it can be powered by an external linear power supply. When powered, verify the voltage at the reader meets the reader's requirements (refer to Table 1 on page 2). When the reader is powered on, its beeper beeps in the following pattern: 3 short beeps, 1 long beep.

P-650 Card+PIN Proximity Reader & Keypad

4.3 Controls

- Beeper (the blue wire): Pull the beeper line low to activate the beeper.
- Single LED Control Line Mode (the brown wire): The normal state is for this line to be high activating the red LED. Pull the Single LED line low to activate the green LED. Pulsing the line results in an amber LED.
- Dual LED Control Line Mode (the brown and orange wires): Pull the Single LED Line low (the brown wire) to activate the red LED. Pull the Dual LED Line low (the orange wire) to activate the green LED. Pull both LED lines low (brown and orange) to activate the amber LED.

4.4 Read Range for P-650 Readers

Perform the following steps to verify the read range¹ of P-650 readers (refer to the Read Range specification section on page 2).

1. Hold a 26-bit Wiegand Card or Tag parallel to the reader, about 6 inches away from the reader.
2. Slowly bring the Card/Tag in toward the reader and note the distance when the reader recognizes the card (the reader beeps and the LED flashes).

The unique construction of the P-650 reader limits the reader's read range. Because of this, Farpointe Data recommends presenting a card or key tag to one of the LEDs at the upper corners of the body of the reader. Figure 3 demonstrates how this is done.

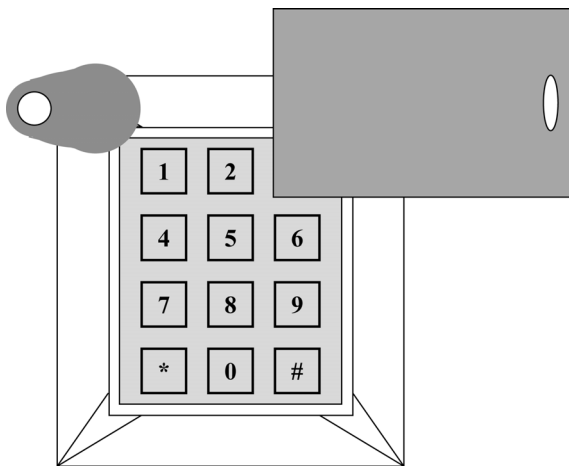

Figure 3: Presenting a Card to a P-650 Reader

1. The Reader's read range can be affected by the installation conditions, the material on which the reader is mounted, and whether it is a card or a tag being read. Due to the physical size difference between the coils of various credentials, Multi Technology cards and Key Tags provide less read range than Standard Light Proximity Cards.



P-650 Card+PIN Proximity Reader & Keypad

4.5 P-650 Card+PIN Operation

1. Present the access card¹ to the reader. A beep will sound and the LED will flash repeatedly.
2. Enter the assigned 4 digit Personal Identification Number (PIN). Each keystroke will generate a beep. You must press the # key after entering a PIN to send data to the access panel. You are given 15 seconds to enter a PIN.
3. If the PIN is correct, there will be one short beep and the LED will turn a steady green to allow entry.
4. If the PIN is incorrect, there will be a short beep and the LED will flash red, then return to amber. You must present the card again and enter the correct PIN to gain access.

NOTE: You must present the access card BEFORE entering a PIN. If any keystrokes are entered before presentation of an access card, press the # key to clear the PIN number buffer then present the access card with valid PIN.

4.6 Notes

The factory default setting for the keypad is 26-bit Wiegand mode and must remain so for proper operation.

1. Only 26-bit Wiegand cards are to be used with the P-650 Proximity Reader and Keypad.

P-650 Card+PIN Proximity Reader & Keypad

5.0 Control Cards

Control cards are specially coded proximity cards that toggle readers between specified modes of operation. To toggle between modes, simply present the control card to the reader. The reader beeps and the LED flashes indicating the control card was recognized and the mode has been changed, but no data is sent to the access panel. Please refer to the Pyramid Series Control Cards Reference Document (P/N 01846-003) for further information on how to use control cards. Control cards must be ordered from your Farpointe Data supplier.

NOTE: Do not use any Proximity Control Cards on the P-650 Card+PIN Proximity Reader and Keypad that are not listed below.

5.1 LED Control Mode Card

Readers can work with access panels configured to drive either Wiegand single or dual LED control line devices. The reader uses the LED Mode control card to change between single and dual line LED control modes. The default setting for the readers is for single LED control line operation.

5.2 Beeper Suppress Control Card

When a cardholder presents a card to a Pyramid Series Reader, the reader beeps and flashes to acknowledge the card. The reader uses a Beeper Suppress control card to toggle the reader's beeper ON and OFF. The default setting for the reader is for the beeper to beep to acknowledge card presentation.

5.3 LED Suppress Control Card

When a cardholder presents a card to the Pyramid Series Reader, the reader beeps and flashes to acknowledge the card. The reader uses an LED Suppress control card to toggle the reader's LED flash feature ON and OFF. The default setting for the reader is for the LED to flash to acknowledge card presentation.

5.4 Data Line Test Control Card

Each Pyramid Series Reader has an internal data line test to verify the reader is able to communicate with the access panel. In this test the reader toggles the data lines (either Data 0 and Data 1 for Wiegand configurations or Data and Clock for magnetic stripe configurations) between high and low states: +5 VDC to 0 VDC. This toggling occurs at a slow rate so that it can be viewed on a DVM. The reader uses a "control" card to start or stop the data line test.

6.0 Troubleshooting the Reader Installation

Table 3: Reader Installation

| Problem | Possible Cause | Corrective Action |
|---|---|--|
| The reader does not recognize a card/tag (no beep, no LED flash). | 1. One or more of the reader's wiring connections are incorrect. | <ul style="list-style-type: none"> Power down the access panel and verify the wiring connections are correct for the reader/access panel combination per the instructions in the <u>Wiring Connections</u> section on page 5. |
| | 2. The reader is not receiving proper power from the access panel. | <ul style="list-style-type: none"> Verify the voltage supplied to the reader is between 5 and 14 VDC. |
| | 3. The reader is mounted too close to a device that radiates electromagnetic interference. | <ul style="list-style-type: none"> Devices such as computer monitors radiate electromagnetic interference that affects read range. When possible, relocate either the reader or the device to provide a greater distance between the two. |
| The reader has a short read range. | 1. The access panel is not properly grounded. | <ul style="list-style-type: none"> Ensure there is a quality earth ground connection made to the access panel. Refer to the access panel's documentation for information regarding the earth ground connection. |
| | 2. The shield wire for the reader's cable has opened somewhere between the reader and the access panel. | <ul style="list-style-type: none"> Verify the shield line from the access panel to the reader is one continuous, connected line. Refer to the access panel's documentation and verify the shield line is correctly connected to the access panel. |
| | 3. The reader is mounted too close to a device that radiates electromagnetic interference. | <ul style="list-style-type: none"> Devices such as computer monitors radiate electromagnetic interference that affects read range. When possible, relocate either the reader or the device to provide a greater distance between the two. |

P-650 Card+PIN Proximity Reader & Keypad

Table 3: Reader Installation

| Problem | Possible Cause | Corrective Action |
|---|--|--|
| | 4. The power supply is generating electromagnetic interference. | <ul style="list-style-type: none"> The power supply on the access panel must be a regulated linear supply – do not use switching supplies as they are often sources electromagnetic interference. |
| Nothing happens when a key is pressed. | 1. The reader is not receiving proper power from the access panel. | <ul style="list-style-type: none"> Verify the voltage supplied to the reader is between 5 and 14 VDC. |
| Nothing happens after a PIN is pressed. | 1. The # key (send) was not pressed after the code was entered. | <ul style="list-style-type: none"> Reenter the code and then press the # key. |

